

**THERMAL PRINTER MECHANISM**

**HTP-9012**

**User Manual**

Reference: FDE-3105726

**Issue C**

January 2009

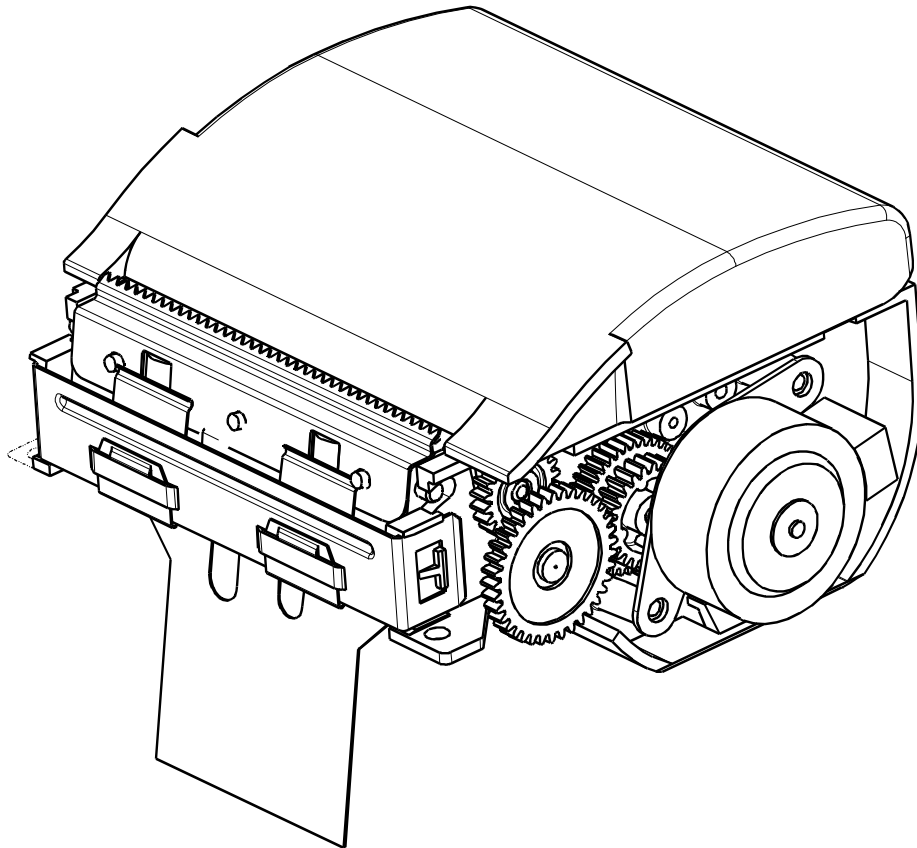

**AXIOHM**

1 Rue d'Arcueil BP 820

92542 Montrouge Cedex, France

Tel : (33) (0) 1 58 07 17 17 Fax : (33) (0) 1 58 07 17 18

## **IMPORTANT**

**This manual contains the basic instructions to run your printer. Read it carefully before using your printer paying full attention to section concerning recommendations.**

**TABLE OF CONTENTS**

<b>1</b>	<b>OVERVIEW .....</b>	<b>4</b>
1.1	UNPACKING .....	4
1.2	SUMMARY OF PRINTER SPECIFICATIONS.....	4
<b>2</b>	<b>MECHANICAL SPECIFICATIONS .....</b>	<b>6</b>
2.1	GENERAL DESCRIPTION .....	6
2.2	DIMENSIONS OF THE COMPLETE MECHANISM :	6
2.3	MECHANICAL VIEWS .....	6
2.3.1	Side view .....	6
2.3.2	Fixing hole position .....	7
2.4	TOP OF FORM MANAGEMENT .....	7
<b>3</b>	<b>ELECTRICAL SPECIFICATIONS.....</b>	<b>8</b>
3.1	NOMINAL POWER SUPPLY.....	8
3.2	NOMINAL CONSUMPTION .....	8
3.3	DESCRIPTION OF PRINthead .....	8
3.3.1	Function of each 64 bit IC (integrated circuit) .....	9
3.3.2	Operation of the complete module.....	10
3.3.3	Electrical specifications of 64-BIT LSI driver.....	11
3.3.4	Printhead Connection.....	13
3.4	BIPOLAR PAPER FEED MOTOR .....	14
3.4.1	Characteristics .....	14
3.4.2	Stepping motor connections.....	14
3.4.3	Induction sequence and timing .....	14
3.4.4	Motor Acceleration Ramp Up.....	15
3.4.5	Bipolar stepping motor electric control.....	16
3.5	MICRO SWITCH CHARACTERISTICS.....	16
3.6	OPTO-SENSOR SPECIFICATION.....	17
3.6.1	Electrical characteristics.....	17
3.6.2	Connection .....	17
3.6.3	External circuit.....	17
<b>4</b>	<b>PRINTER CONTROL TECHNIQUES .....</b>	<b>18</b>
4.1	MODE 1.....	18
4.2	MODE 2.....	19
4.3	MODE 3.....	20
<b>5</b>	<b>RECOMMENDATIONS .....</b>	<b>21</b>
5.1	MECHANICAL RECOMMENDATIONS .....	21
5.2	HOUSING DESIGN RECOMMENDATIONS .....	21
5.3	ENERGISING & DE-ENERGISING PRINTER .....	21
5.4	RECOMMENDATIONS FOR PAPER.....	21
5.5	GENERAL .....	22
5.6	CLEANING RECOMMENDATIONS.....	22
<b>6</b>	<b>PAPER SUPPLIERS &amp; SPECIFICATIONS.....</b>	<b>23</b>
<b>7</b>	<b>SPARE PARTS .....</b>	<b>24</b>
<b>8</b>	<b>APPENDICES .....</b>	<b>25</b>
8.1	APPENDIX 1 : THERMISTOR SPECIFICATIONS .....	25
8.2	APPENDIX 2 : HEATING TIME AND HISTORICAL CONTROL.....	27
8.3	APPENDIX 3 : FIT OR CHANGE THE PRINthead .....	30
8.4	APPENDIX 4 : FIT OR CHANGE THE COVER .....	30

## 1 OVERVIEW

### 1.1 UNPACKING

Each printer mechanism is packaged in an antistatic bag. Observe precautions for handling in electrostatic protected areas.

### 1.2 SUMMARY OF PRINTER SPECIFICATIONS

Based on static thermal printing technology, the HTP-9012 mechanism is user-friendly, highly reliable device which uses the easy paper loading Clamshell system. It contains a paper bucket.

Very small size printer mechanism.  
 Silent mechanism  
 8 dots/mm print-heads  
 Tear bar

#### SUMMARY OF PRINTER SPECIFICATIONS

ITEM	VALUE	UNITS
	HTP-9012	HTP-9012
Printing method	Static thermal dot line printing	-
Number of resistor dots	384	-
Resolution	8	Dots/mm
Printing width	48	mm
Paper width	60	mm
Head temperature detection	By Thermistor	-
Number of steps / dot line	1	-
Paper feed / dot line	0.125	mm
Paper empty detection	Opto-sensor	-
Operating voltage range Vcc (logic)	4.75-5.25	V DC
Operating voltage range Vch (dot)	10 to 15.2 operating (16 stand by)	V DC
Peak printhead current (all dots "on" at nominal value )	10.8	A

Current consumption: V ch (at nominal value)	25	mA per resistor dot "on "
Current consumption: V cc (at nominal value)	100	μA
Current consumption: Stepping motor (for paper feed)	300	mA per phase
Storage range	- 20 to + 60	°C
Operating range	-20 to +70 (**)	°C
Electrical life time*	10 <sup>8</sup>	pulses
Mechanical life time*	50	Km
Relative humidity	10 to 85 no condensing	%
Over all dimensions:		
Width	91.3	mm
Depth	76.5	mm
Height	55	mm
Weight	150	g
Recommended paper	Kanzan KP440 & P350	-
Maximum paper thickness	80	μ

\* Per AXIOHM standard test conditions (which are mainly: 12V, 25°C, dot printing duty cycle = 25 %)

\*\* It is necessary to pre heat the thermal print head at -20°C

## 2 MECHANICAL SPECIFICATIONS

### 2.1 GENERAL DESCRIPTION

The mechanism consists in :

- Plastic bucket with paper reservoir
- Stepping motor
- Drive gear
- Printhead with end of paper optical-sensor and flex cable for connection

### 2.2 DIMENSIONS OF THE COMPLETE MECHANISM :

Height : .....	55	mm
Depth : .....	76.5	mm
Width : .....	91.3	mm
Weight : .....	150	g

### 2.3 MECHANICAL VIEWS

#### 2.3.1 Side view

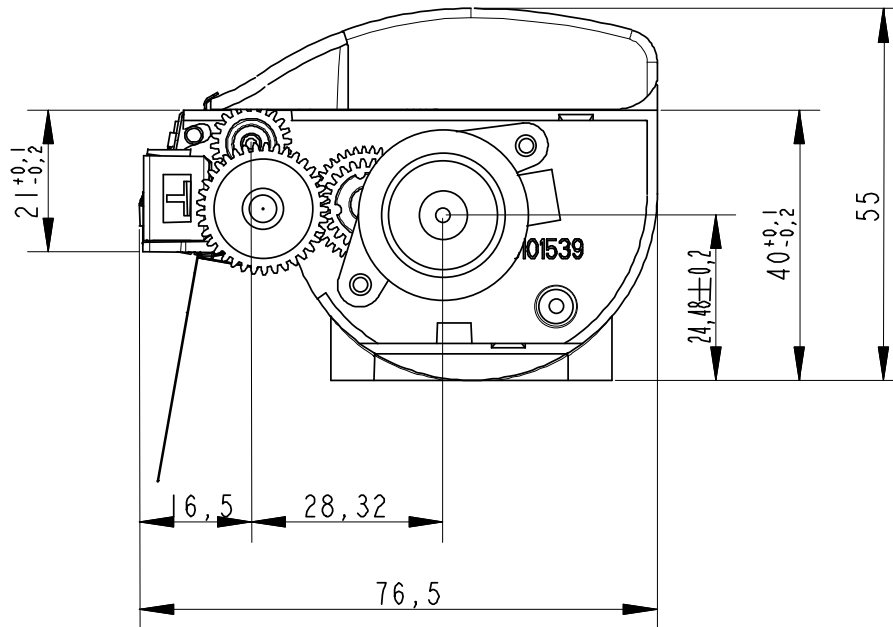

Note : the motor diameter is 25 mm

### 2.3.2 Fixing hole position

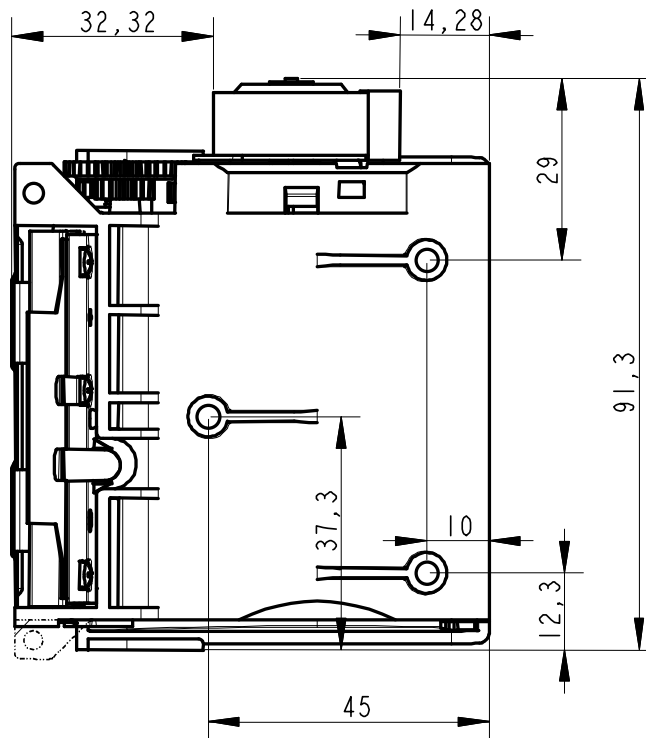

The 3 inserts are designed to assemble the printer to the user set. They can accept M2.5 and M2.6 screws. The screws should not be screwed longer than 4 mm inside bucket. The maximum acceptable torque is 0.2 Nm. **The maximum pulling effort is 50 N by insert. Screwing outside of these maximum values may destroy the bucket.**

## 2.4 TOP OF FORM MANAGEMENT

A hole or a black mark can be set on the paper at the position and with the size given here after so that it can be detected by the optical sensor (also used as end of paper sensor). This allows to manage specific positioning on ticket if required.

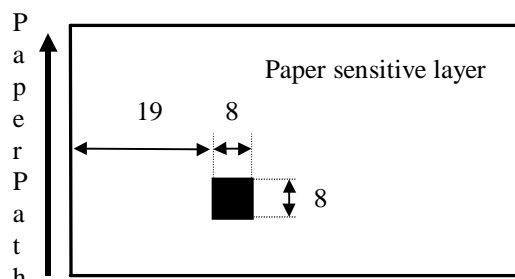

### 3 ELECTRICAL SPECIFICATIONS

#### 3.1 NOMINAL POWER SUPPLY

Printer	HTP-9012	Units
Printhead : Logic (Vcc) Dot line	5 12	V DC V DC
Stepping motor	12	V DC

#### 3.2 NOMINAL CONSUMPTION

Printer	HTP-9012	Units
Printhead : Heating current / dot (Vch) at nominal values	28	mA
Logic current / dot (Vcc)	100	μA
Stepping Motor (2 activated phases) ( for paper feed)	600	mA
Maximum instantaneous current per dot line (at 24V)	10.8	A

#### 3.3 DESCRIPTION OF PRINTHEAD

Printer	HTP-9012	UNIT
Driver chips (64 bit BiCMos LSI)	6	-
Mean dot resistance (+ 10 %)	480	ohms
Nominal dot energie (in standard conditions)	0.31	mJ
Max printing speed (with 12V power supply) *	70	mm/sec

\* The printing speed of the mechanism depends on three main parameters : the driving software of the mechanism, the paper sensitivity, and the temperature at which the mechanism is used (see the chapter "heating time" for more details on this topics).

### 3.3.1 Function of each 64 bit IC (integrated circuit)

#### Driver IC schematic

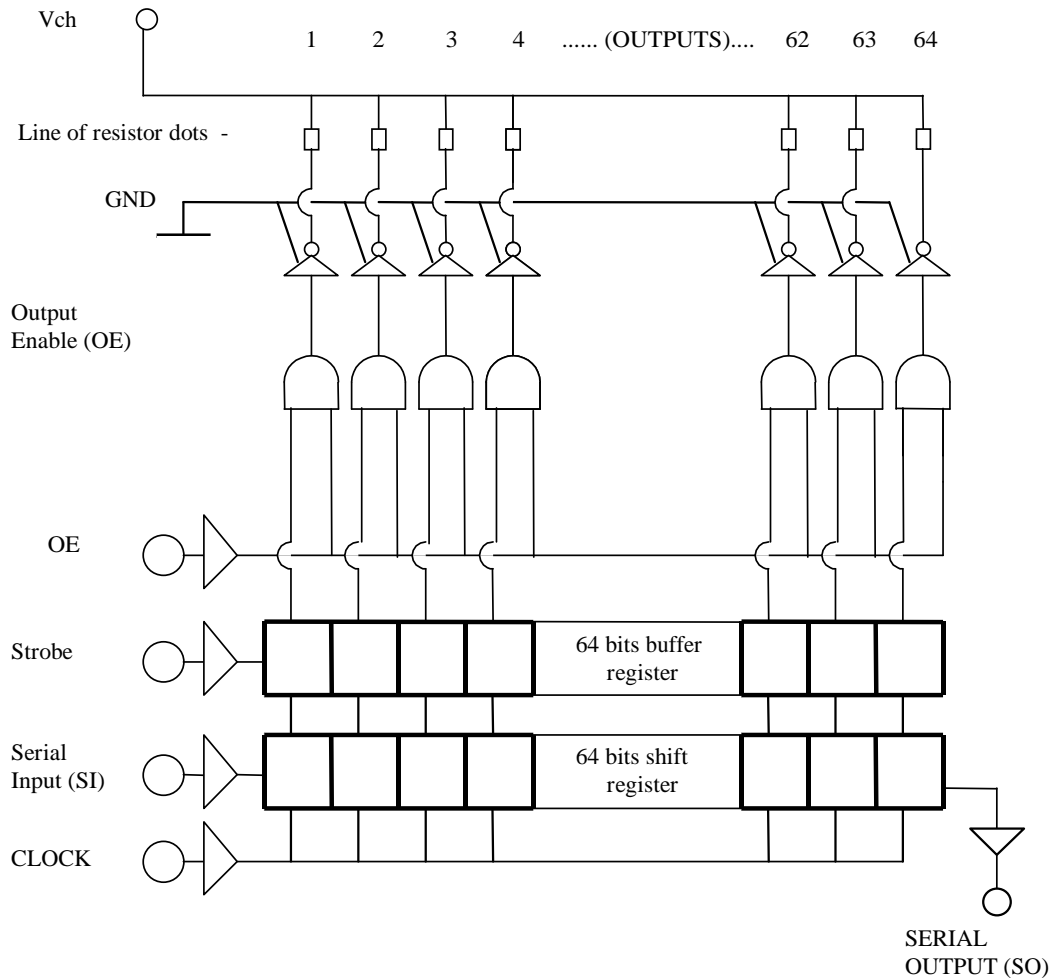

<b>These circuits are supplied by</b>	<b>5V +/- 5% logic voltage</b>
<b>Each circuit features</b>	<b>64 open collector transistors</b>
	<b>64-bit shift register</b>
	<b>64-bit memory register</b>
<b>Each circuit controls</b>	<b>64 resistor dots on the printhead</b>

The heating element power supply VCH is not connected to the Driver ICs but only to the resistive line of dots itself. The driver ICs are connected via a pattern of high current gold interconnecting traces to the line of resistor dots.

The dot line is of the interdigitated type, in order to maintain the tight definition of the dot geometry and resistance. In such a scheme the heating element power supply VCH forms a 'comb' of traces over which the resistive line of dots is laid. The outputs of the driver ICs form a second comb interdigitated with the first.

### 3.3.2 Operation of the complete module

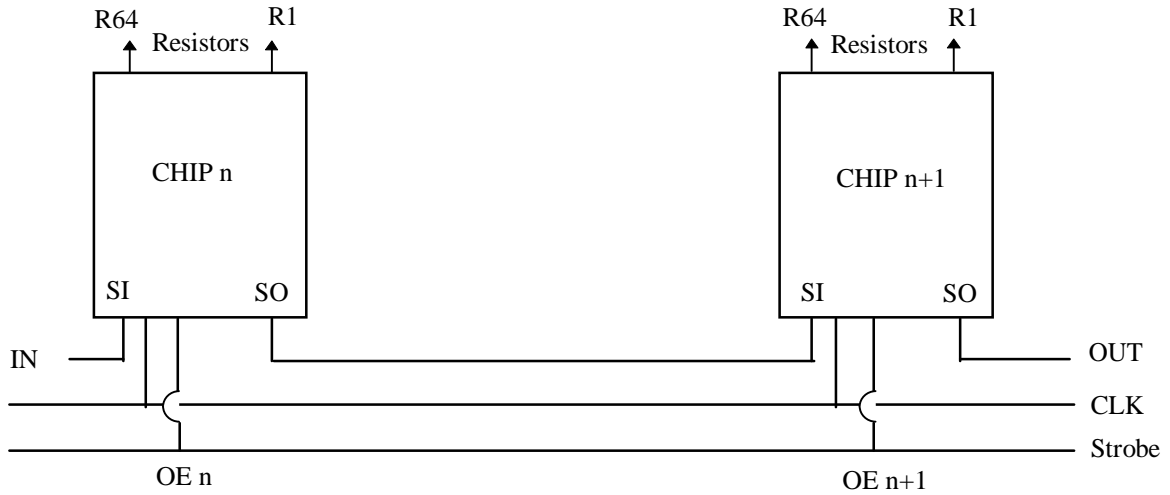

- Data to be printed is clocked into a shift register formed by cascading "n" chips.
- E.g. 384 dot head uses 6 chips with the SO output of chip 1 used as the SI input for chip 2 etc. Respectively, the SO output of chip 2 is used as the SI input for chip 3 etc.

After 384 clocks, the initial piece of data entered corresponds to the last (384<sup>th</sup>) dot of the line (the R64 output of the 6<sup>th</sup> chip). The last bit of data entered will correspond to the first dot of the line (R1 of the first chip).

#### Routing of data to the resistor dots :

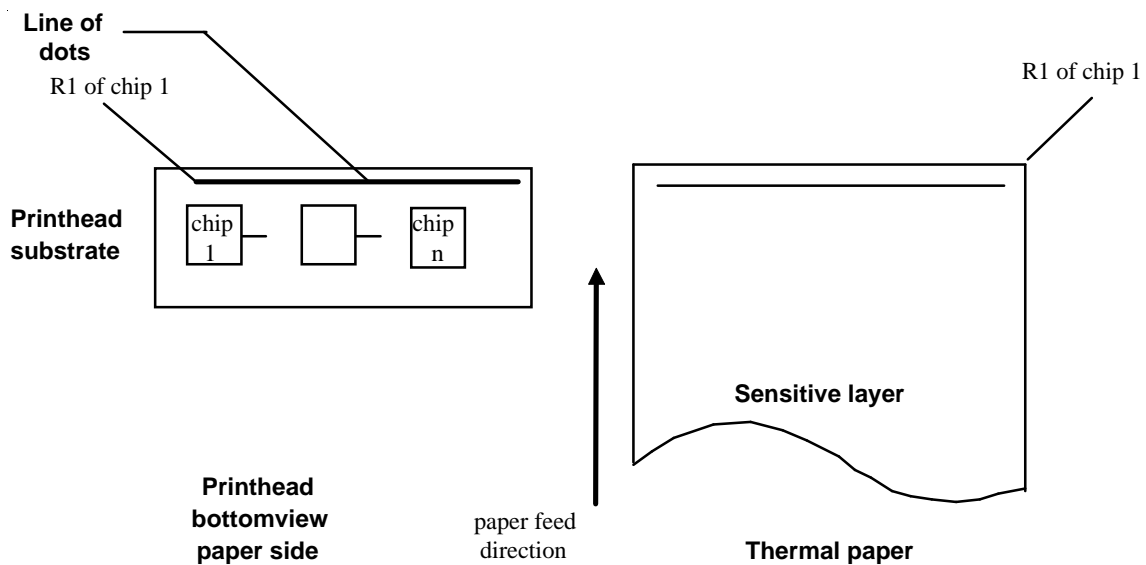

### 3.3.3 Electrical specifications of 64-BIT LSI driver

#### 3.3.3.1 General

PARAMETER	HTP-9012		UNIT
	MIN	MAX	
Max.voltage at outputs 1 to 64		16	V
Max.input voltage		Vch	V
Max.output current/dot		28	mA
Total max.output current		10.8	A

#### 3.3.3.2 Other

The specifications given below are given for the following conditions :

- Room temperature
- Logic voltage on chip :  $4.75\text{ V} < V_{dd} < 5.25\text{ V}$ ,
- Clock frequency : 4MHz

Logic Current (5 V)	HTP-9012		Symb
	Conditions	Values	
Current per controlled element (dot)	-	-	I <sub>dd</sub>
Min.high-level input voltage	V <sub>cc</sub> = 5V	0.7V <sub>cc</sub>	V <sub>ih</sub>
Max.low-level input voltage	V <sub>cc</sub> ≤ 5V	0.3 V <sub>cc</sub>	V <sub>il</sub>
Max.high-level input current		0.5μA	I <sub>ih</sub>
Max.low-level input current		0.5μA	I <sub>il</sub>
Min.high-level output voltage	V <sub>cc</sub> = 4.5	4.45 V	V <sub>oh</sub>
Max.low-level output voltage	V <sub>cc</sub> = 4.5	0.05 V	V <sub>ol</sub>
Max.high-level output current	-	-	I <sub>ohmax</sub>
Max.low-level output current	-	-	I <sub>olmax</sub>

Heating current	Conditions	Values	Symb
Max.power output current	V <sub>don</sub> =V <sub>donmax</sub>	27,3 mA	I <sub>domax</sub>
Max.output leakage current	V <sub>don</sub> =24 V	10 μA	I <sub>doleak</sub>
Max.output voltage	I <sub>dout</sub> =I <sub>domax</sub>	800 mV	V <sub>donmax</sub>

### 3.3.3.3 Timing

#### Timing diagram for HTP-9012

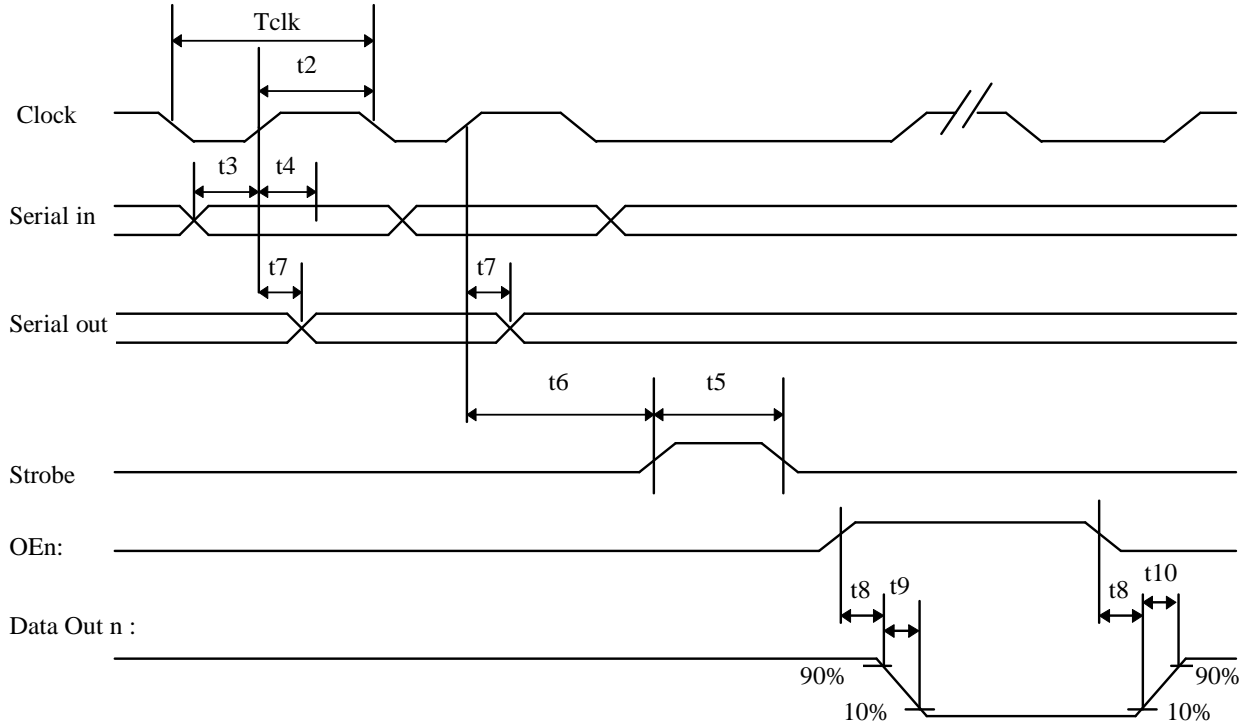

Sym	Description	Min	Max	Unit
<b>Tclk</b>	<b>Serial clock period</b>	<b>25</b>		<b>ns</b>
<b>t2</b>	<b>Clock pulse width</b>	<b>70</b>		
<b>t3</b>	<b>Data in to clock setup time</b>	<b>50</b>		<b>ns</b>
<b>t4</b>	<b>Data in from clock hold time</b>	<b>10</b>	<b>220</b>	<b>ns</b>
<b>t5</b>	<b>Strobe high time</b>	<b>100</b>		<b>ns</b>
<b>t6</b>	<b>Clock to strobe delay time</b>	<b>100</b>		<b>ns</b>
<b>t7</b>	<b>Serial data out from clock delay</b>		<b>120</b>	<b>ns</b>
<b>t8</b>	<b>OE to data out delay time</b>		<b>2</b>	<b>µs</b>
<b>t9</b>	<b>Data out fall time, 10% -&gt; 90%</b>		<b>0.5</b>	<b>µs</b>
<b>t10</b>	<b>Data out rise time, 10% -&gt; 90%</b>		<b>2</b>	<b>µs</b>

### 3.3.4 Printhead Connection

#### PINOUT OF 26 WAYS FLEX CABLE

1	VCH	2	VCH
3	VCH	4	Data In
5	OE 1	6	Strobe
7	GND	8	GND
9	Clock	10	OE 2
11	GND	12	GND
13	Thermistor 1	14	Thermistor 2
15	Vcc (V logic)	16	OE 3
17	Optical sensor Anode	18	Optical sensor Collector
19	GND	20	GND
21	GND	22	OE 4
23	Data Out	24	VCH
25	VCH	26	VCH

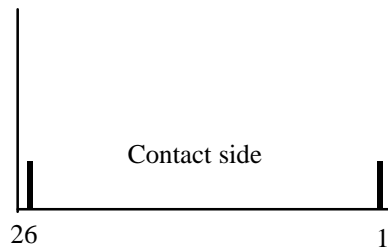

The printhead flex can be connected to the following connectors references :

Supplier	References *
Molex	5597 39-51-3264 5597 30-51-7263
Stocko	MZF 9386-6-0-2626 MZF 8896-6-0-2626

\* Two references are given for each supplier : one for straight connector and one for 90° bent connector.

The Connector requested : 26 pins, step of 1,25 mm, Zero insertion force. Note that using any other connector can destroy the flex cable.

### 3.4 Bipolar paper feed motor

#### 3.4.1 Characteristics

- Recommended control voltage : 12V
- Coil resistance :  $20 \Omega \pm 7\%$
- Number of phases : 2
- Step angle :  $7^\circ 30'$
- Paper feed for one printing line : 1 (= 0.125 mm)
- Recommended control current per phase : 300 mA (peak)
- Maximum starting frequency : 400 pps

#### 3.4.2 Stepping motor connections

length of the leads:  $100 \pm 10$  mm  
 Connector : 6 pins top entry type J.S.T ref. B6B-PH-K-S  
 Pinout : pin 1,2 : first winding  
           pin 3,4 : second winding  
           pin 5: Door switch  
           pin 6: Door switch ground

PIN n°	Wire color	Motor
1	black	A1
2	brown	A2
3	yellow	B2
4	orange	B1
5	switch	
6	switch	

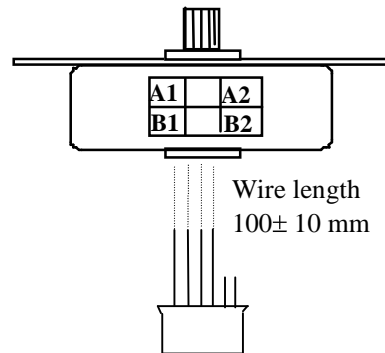

#### 3.4.3 Induction sequence and timing

	BLACK	YELLOW	BROWN	ORANGE
STEP 1	—	—	+	+
STEP 2	—	+	+	—
STEP 3	+	+	—	—
STEP 4	+	—	—	+

Voltage on cable is negative where shown as “-“.  
 Voltage on cable is positive where shown as “+”.

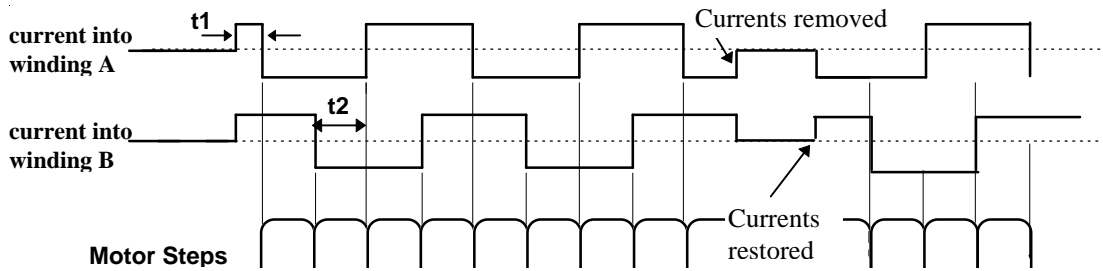

- There are 4 different conditions for the motor windings:

The sequence is :

$$AB \Rightarrow \bar{A}\bar{B} \Rightarrow \bar{A}B \Rightarrow A\bar{B} \Rightarrow AB$$

Where

$\bar{A}\bar{B}$  stands for "A is positive and B is negative" etc.

- This electrical sequence corresponds to a sequence of 4 consecutive mechanical positions. The sequence is repeated 12 times for each revolution.

-  $t_1 = 0,4$

-  $t_2 \geq 2 \text{ ms}$

Motor initialisation

Once the initial winding currents have been applied they must be maintained for a time  $t_1$ . Once this time has passed the motor may be operated by changing the winding currents in the usual way.

To take-up the play in the gears it is necessary to operate the motor for 16 steps before starting to print.

### 3.4.4 Motor Acceleration Ramp Up

To reach high printing speed it is recommended to achieve an acceleration ramp up with the paper feed motor. This allows to start below the maximum starting frequency of the motor, to have enough torque and to obtain a good printing quality when the printing and paper feeding start simultaneously.

The next table is given as an example that can be adapted depending on the required application, and required speed to reach. The first row shows the motor pitch, and the second one shows the motor phase time in  $\mu\text{s}$ .

This table is given to reach 100 mm/s (1250  $\mu\text{s}$  which means 800 pps) with 11 motor steps.

step	1	2	3	4	5	6	7	8	9	10	11
time	5000	4160	3120	2500	2270	2030	1610	1440	1320	1280	1250

### 3.4.5 Bipolar stepping motor electric control

#### Example of motor external circuit

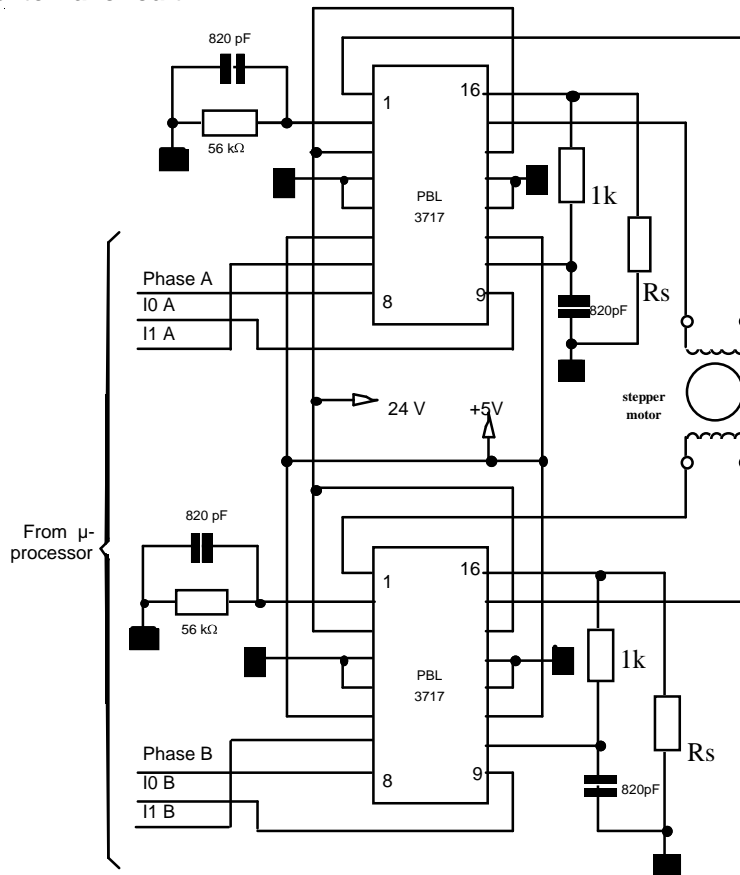

Note 1 :  $R_s$  : resistors of 0.8 ohm  
with  $I_{0A}$  and  $I_{0B} = 1$  and  
 $I_{1A}$  and  $I_{1B} = 0 \rightarrow I = 0,3$  A (the required control current for paper feed).

Note 2 : to obtain 0.8  $\Omega$  (which is not standard) it is possible to set 1 $\Omega$  and 4.75 $\Omega$  in parallel.

- For other stepping motor control requirements, please contact us.

### 3.5 Micro switch Characteristics

Contact resistance :  $< 1 \Omega$   
Maximum rating : 0.1 A -30 V DC

#### Connection

Leads length :  $110 \pm 10$ mm  
Connector : Together with motor (see "stepping motor connection")

	Door
Switch	open
Switch	closed

### 3.6 Opto-sensor specification

#### 3.6.1 Electrical characteristics

Absolute Maximum ratings					
IF (mA)	VR (V)	PD(mW)	VCEO(V)	IC(mA)	PC(mW)
50	5	75	30	20	75

VF (V)	IR (μA)	ICEO (A)	Io (mA)	VCE(sat)(v)	tr (μs)
IF = 4 mA	VR = 5 V	VCEO = 10V	VCE = 5 V IF = 4 mA	-	IC = 0.1 mA RL = 1 kΩ
Maxi 1.2	Maxi 10	Maxi 1.10 <sup>-7</sup>	Typical 100	-	Typical 30

#### 3.6.2 Connection

Connected to the printhead flex cable.(see page 13).

#### 3.6.3 External circuit

##### Example of optical sensor external circuit

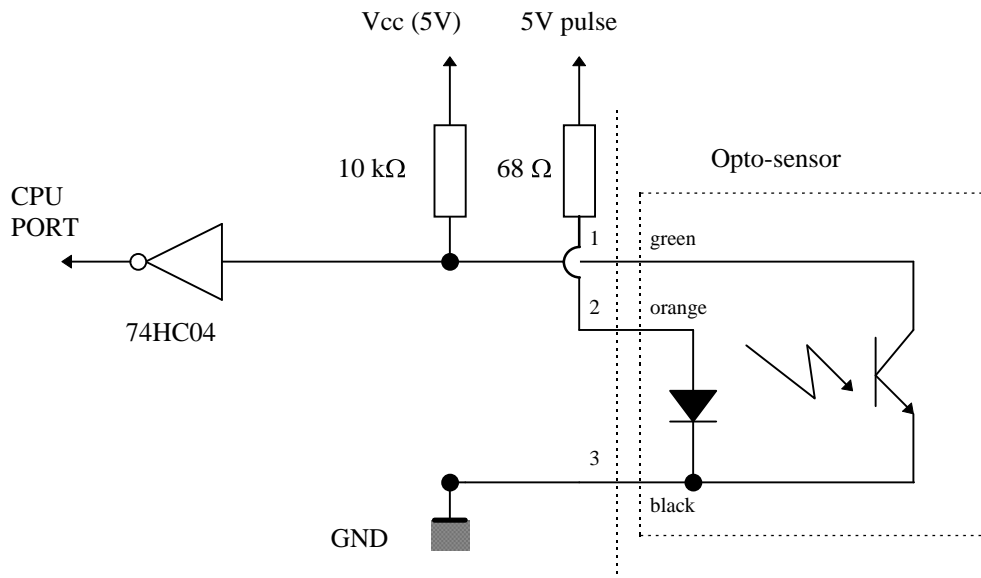

## 4 PRINTER CONTROL TECHNIQUES

Printer control techniques in order to operate the printer. We depict hereafter three possible modes.

### 4.1 Mode 1

- The paper feeds itself automatically during the heating cycle thereby permitting a high speed to be achieved. To achieve the maximum printing speed and with the best quality in this mode, it is recommended to manage historical control of the dots. The nominal heating time is decreased when the dot has been previously heated (see section "Heating time table").

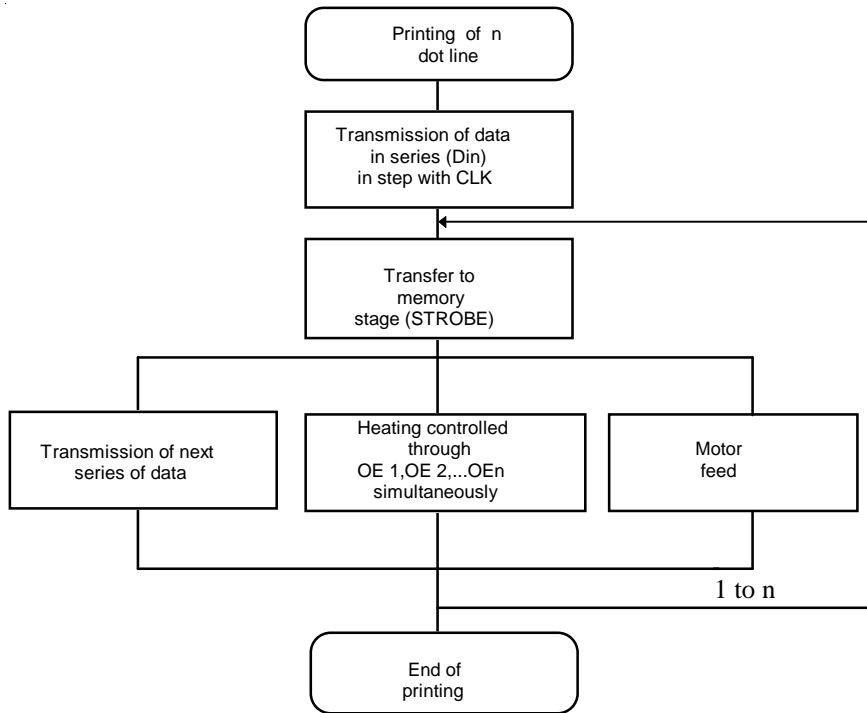

### Timing diagram for mode 1

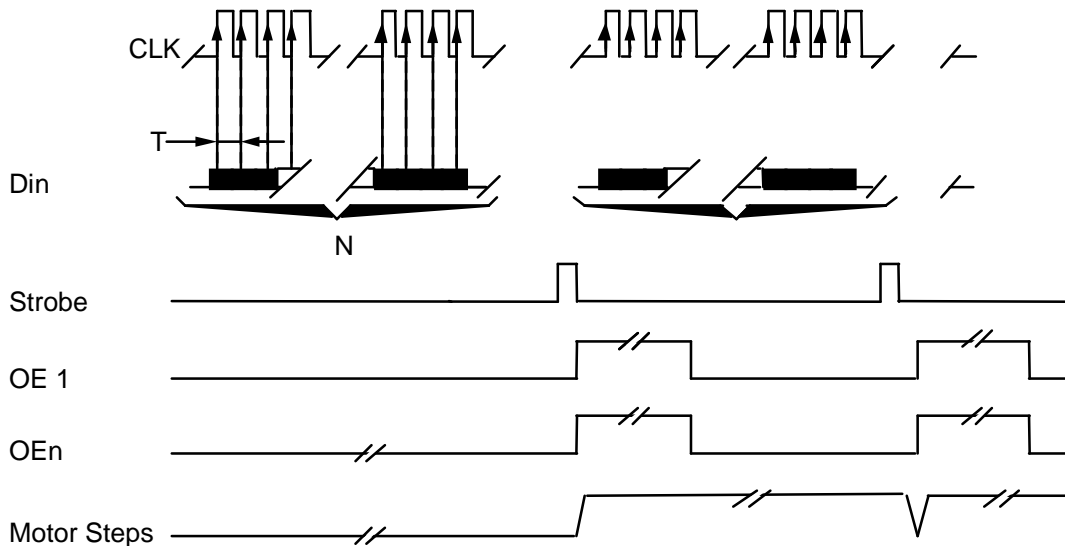

T : Maximum clock frequency 4MHz

## 4.2 Mode 2

The paper feed occurs after the heating cycle giving high quality printing.

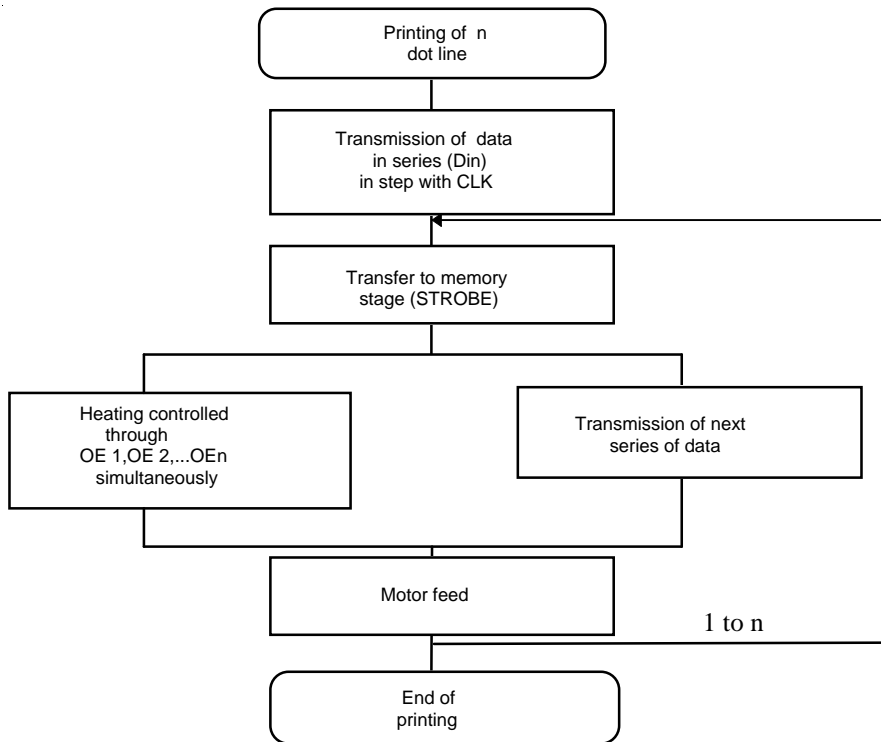

### Timing diagram for mode 2

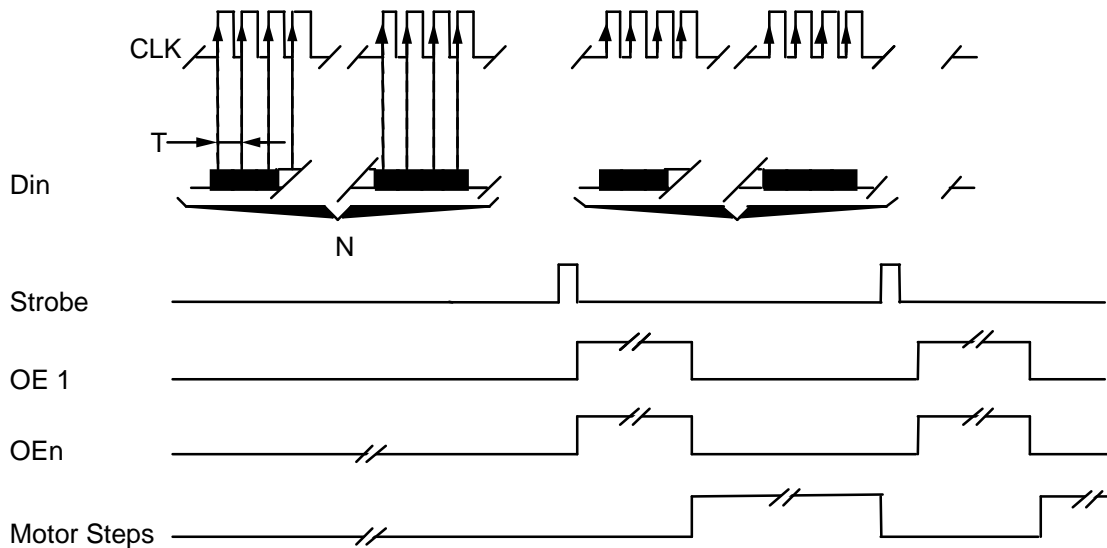

T : Maximum clock frequency 4MHz

### 4.3 Mode 3

This mode is used in conditions where there is a limit of electrical current. The dot line is printed in stages heating only a portion of the line at a time, effectively giving reduced consumption.

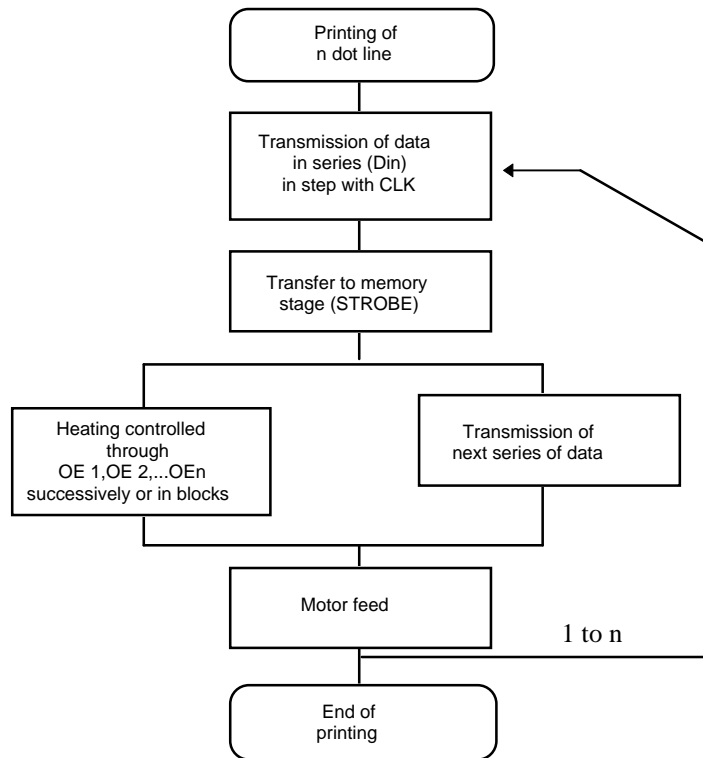

### Timing diagram for mode 3

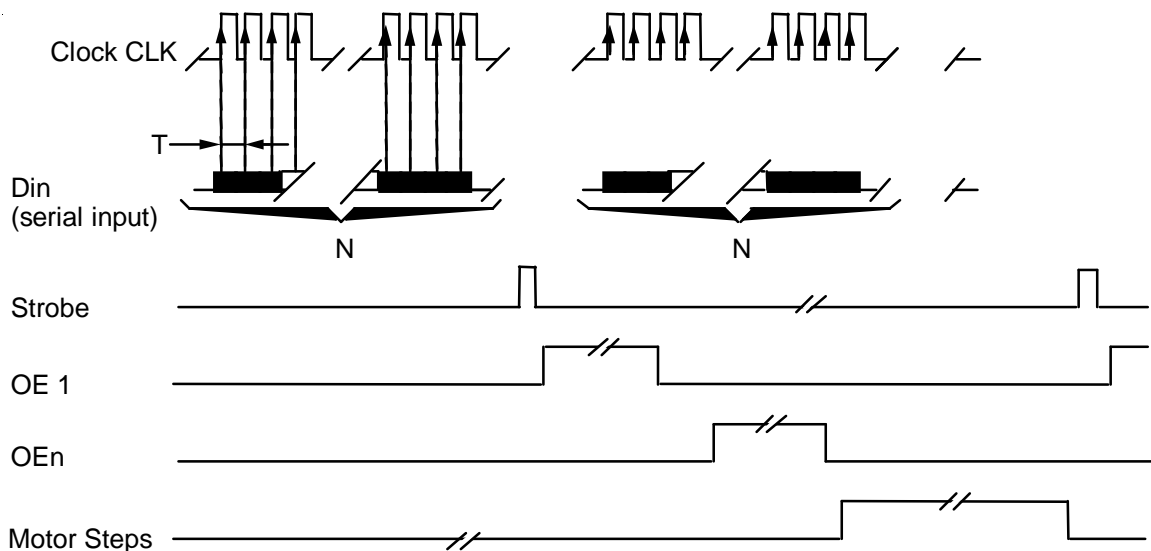

T : Maximum clock frequency 4MHz

## 5 RECOMMENDATIONS

### 5.1 Mechanical recommendations

Never apply mechanical stress to the printer, this could result in misalignment and thus degradation of the print quality.

The thermal printhead must have 1 degree of freedom. Never hinder the printhead from pivoting on its axis.

### 5.2 Housing design recommendations

See the chapter concerning the fixation position, make sure it is easy enough to release printer, this operation is necessary for easy maintenance.

It is necessary to leave enough place to catch the cover in order to open it.

### 5.3 Energising & de-energising printer

When energising the thermal printhead ( $V_{cc}$ , 5 V) it is important to apply all the logic signals within 10 ms (particularly to de-energise all the OEs).

If the line of dots ( $V_{ch}$ , 12 V) is supplied before the control logic, resistor dots may be destroyed. Because the control logic has a random state, resistors might be heated for a longer period than the specified maximum, burning out the heated resistor.

To avoid this, we recommend applying the heating voltage ( $V_{ch}$ ) after the logic supply voltage ( $V_{cc}$ , 5V).

When first applying  $V_{ch}$  make sure the OEs level is 0 to avoid the dot heating before sending data.

The same precaution should be taken when shutting down. The supply voltage  $V_{ch}$  must be switched off before the logic supply voltage  $V_{cc}$ . Care should be taken to allow enough time for residual capacitive charge to dissipate.

### 5.4 Recommendations for paper

Use a paper use recommended (or approved) by AXIOHM.

Use a paper roll with a maximum diameter of 50 mm to fit in the bucket.

The paper must have the recommended width to be well laterally guided.

The printer should not operate without paper, this might damage the surface of the platen and can also destroy the dot resistors because of a bad thermal transfer.

Paper with bad factor may affect the printhead life

## 5.5 General

- Ensure that there is adequate air circulation around the printhead support/heatsink as poor ventilation of the printhead can degrade the print quality.
- Do not open the cover while the mechanism is printing.
- It is very important that the radiator is connected to the frame.
- In order to avoid excessive noise from the stepper motor, avoid using it at the following frequencies : between 150 and 250 pps.
- When continuous printing is performed, the supply energy should be reduced so that the head temperature monitored through the thermistor will remain below the maximum temperature.
- When setting 'power on / power off', strobe (STR) shall be on 'disable'.
- Heat elements and IC's shall be anti-electrostatic in order to prevent electrostatic destruction. Do not touch the connector pins with fingers.
- Make sure no foreign particles roll on the head surface, this would cause damage.
- If condensation occurs, do not switch on the printer until it has disappeared.
- When used continuously, it is recommended to set a duty cycle time to avoid overheating of the paper feed motor. This cycle has to be determined with the application as it depends on the housing in which the mechanism is integrated. Two parameters have to be determined : the duty cycle and the maximum time "on". This has to be considered specially when an end of day journal is achieved.

## 5.6 Cleaning recommendations

The HTP-9012 printer is a high reliability unit which requires very little maintenance but may benefit from cleaning as detailed below.

Depending on the environment in which the printer is used , the printer can accumulate dust. Therefore it is necessary to clean it periodically in order to maintain a good print quality. The cleaning period is dependant on the environment and the usage of the printer, but the printhead should be cleaned at least once a year or up to one month in heavy duty applications. The printhead should always be cleaned immediately if the print becomes visibly fainter due to its contamination.

### Cleaning Instructions :

- **Switch off printer.** Never clean the head immediately after printing, the head may be hot.
- **Open the printer cover and remove the paper from its slot.**
- **Clean the heating dots of the head with a cotton stick containing a solvent alcohol (ethanol, methanol, or IPA) but do not touch the printhead with your fingers !**
- **Allow the solvent to dry.**
- **Reload the paper and close cover.**

**N.B** AXIOHM is able to provide cleaning kits Ref : **CK60000A** (operating process is described on the packaging)

## 6 PAPER SUPPLIERS & SPECIFICATIONS

Different papers can be used such as Kanzan KP440, Jujo TF50KS E2. The heating time, thus the printing speed will vary depending on their sensitivity.

The paper used to achieve the heating time table (see appendix "Heating Time") is Kanzan P350.

- Typical Properties of Kanzan P350 :

Topic	Test Method	Unit	Value
Basis Weight	TAPPI T-410	g/m <sup>2</sup>	54
Calliper	TAPPI T-411	Microns	58
Brightens	TAPPI T-525	%	84
Smoothness	TAPPI T-479	sec	365
Image color	-	-	Black
Initial activation temperature	O.D. = 0.2	°C	70 ± 5
Effective activation temperature	O.D. = 0.8	°C	85 ± 5
Optimum activation temperature	O.D. = 1.2	°C	90 ± 5

- Typical Properties of Kanzaki : KP440

Property	Test Method	Unit	Value
Grammage	ISO 536	g/m2	58 ± 5
Thickness	ISO 534	µm	60 ± 5
Surface smoothness	ISO 5627	sec	250 min.
Brightness	ISO 2470	%	75 min
Tensile strength	ISO 1924	KN/m	3.3 min
Static initial activation temperature	OD = 0.2	°C	50
Static activation temperature	OD = 1	°C	98
Tear Strength	ISO 1974	mN	250 min
Image Colour	-	-	Black
Moisture stability	ISO 287	%	6.5 ± 1

## 7 SPARE PARTS

There is a possibility of obtaining 3 different spare parts kits.

**Mechanism Kit :** This kits contains the plastic bucket, the paper feed motor and the gear train.

MECHANISM KIT	
REF	DESIGNATION
3105770	Mechanism Kit for HTP-9012

**Print- head Kits :** those kits contain the print-head, the flexible and the optical sensor.

PRINT-HEAD KIT	
REF	DESIGNATION
3105771	Print-head Kit for HTP-9012 (8 dots/mm, 12V)

**Cover with platen :** the platen is integrated to the cover

COVER WITH PLATEN KIT	
REF	DESIGNATION
3105772	Cover with platen kit

## 8 APPENDICES

### 8.1 APPENDIX 1 : THERMISTOR SPECIFICATIONS

GENERAL CHARACTERISTICS	HTP-9012
Maximum operating temperatures	-20° C to + 80° C
Rated resistance at 25° C	Rn = 100 kΩ
Tolerance for Rn	5 %
Thermal dissipation factor	$\theta_{JA} = 5 \text{ mW/}^\circ\text{C}$
Thermistor time constant/dot line	t = 30 sec
Resistance value as a function of temperature (see curves)	

This thermistor has a rated value of 100 kΩ. Its resistance variation can be expressed as follows :

$$R = R_n \exp B \left( \frac{1}{T} - \frac{1}{T_n} \right) \quad \text{where } T \text{ is in kelvin degrees (}^\circ\text{K)}$$

$$B = 4066^\circ \text{ K}$$

Rn = reference value at temperature Tn (295° K)

The thermistor response curve is shown on the next page.

APPENDIX 1 (Contd.)

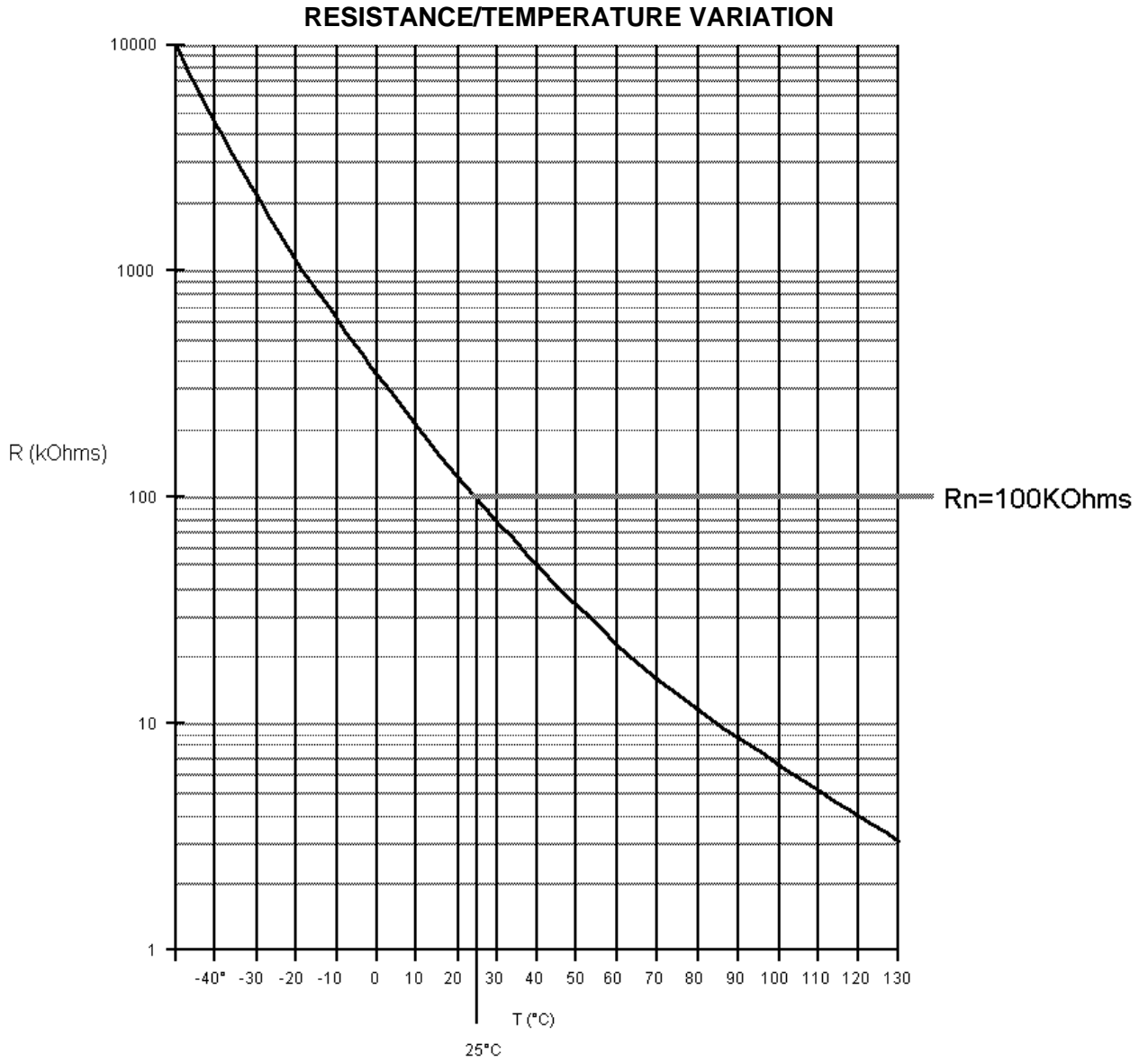

## 8.2 APPENDIX 2 : HEATING TIME AND HISTORICAL CONTROL

Heating time table are given on next page

The motor cycle time for one dot line is given in the second top line of tables, it is the time for one motor step.

The column 3 (indicated with : speed <xxx mm/s and motor cycle time > xxx ms) gives the required heating time, giving the necessary energy to obtain an optical density of 1.2.

Three areas are then defined in the heating time table :

### Area 1 : "white"

The motor cycle time (**tm**) for one dot line (line2) is greater than the heating time indicated in column 3

### Area 2 : high lighted

The heating time (**tch**) in column 3 is greater than the motor cycle time

### Area 3 : (indicated by \* )

The indicated heating time (depending on speed, voltage and temperature) would be greater than the motor cycle time.

In areas 1 and 2, heating time can be controlled either with or without historical control.

**In areas 3, printer cannot be operated.**

### How to use tables ?

**- Without historical control :** apply the indicated heating time given as a function of speed, voltage and temperature. At high speed, printing quality for isolated dots might be affected with this method.

Example : in table at 50 mm/s, 20°C and 12 volts, heating time = 1.59 ms

**- With historical control in area 1:** apply the indicated heating time (function of speed, voltage and temperature) when the dot has been heated on the previous dot line, and the time from column 3 when it has not. This method gives the best printing quality.

Example: at 70 mm/s, 40°C and 12 volts :

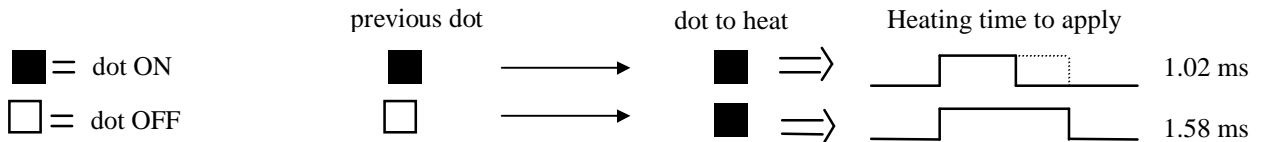

**- With historical control in area 2 :** apply the indicated heating time (function of speed, voltage and temperature) when the dot has been heated on the previous dot line, and the motor cycle time when it has not. At high speed, printing quality for isolated dots might be slightly affected with this method.

Example: at 80 mm/s, 25 °C and 12 volts :

■ = dot ON  
□ = dot OFF

previous dot

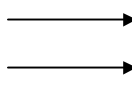

dot to heat

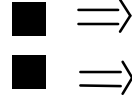

Heating time to apply

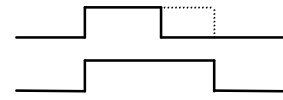

0.88 ms

1.39 ms

Heating time for HTP-9012 (with paper P 350 and print-head resistance = 447 Ω)

Voltage	Temp. °C	Motor cycle time (ms) & Printing speed (mm/s)							
		4,170 ms	3,130 ms	2,500 ms	2,080 ms	1,790 ms	1,560 ms	1,390 ms	1,250 ms
		< 30 mm/s	40 mm/s	50 mm/s	60 mm/s	70 mm/s	80 mm/s	90 mm/s	100 mm/s
10	0 °C	3,570	3,130	*	*	*	*	*	*
10	10 °C	3,240	2,850	*	*	*	*	*	*
10	20 °C	2,920	2,570	<b>2,290</b>	2,070	*	*	*	*
10	25 °C	2,760	2,430	<b>2,170</b>	1,950	<b>1,780</b>	*	*	*
10	30 °C	2,600	2,290	<b>2,040</b>	1,840	<b>1,670</b>	1,520	*	*
10	40 °C	2,280	2,010	<b>1,790</b>	1,610	<b>1,470</b>	1,340	<b>1,220</b>	1,120
10	50 °C	1,960	1,720	<b>1,540</b>	1,390	<b>1,260</b>	1,150	<b>1,050</b>	0,960
11	0 °C	2,950	2,590	<b>2,310</b>	2,080	*	*	*	*
11	10 °C	2,680	2,360	<b>2,100</b>	1,890	<b>1,720</b>	*	*	*
11	20 °C	2,420	2,120	<b>1,890</b>	1,710	<b>1,550</b>	1,410	<b>1,300</b>	1,190
11	25 °C	2,280	2,010	<b>1,790</b>	1,610	<b>1,470</b>	1,340	<b>1,220</b>	1,120
11	30 °C	2,150	1,890	<b>1,690</b>	1,520	<b>1,380</b>	1,260	<b>1,150</b>	1,060
11	40 °C	1,890	1,660	<b>1,480</b>	1,330	<b>1,210</b>	1,100	<b>1,010</b>	0,930
11	50 °C	1,620	1,420	<b>1,270</b>	1,140	<b>1,040</b>	0,950	<b>0,870</b>	0,800
12	0 °C	2,470	2,170	<b>1,940</b>	1,750	<b>1,590</b>	1,450	<b>1,330</b>	1,220
12	10 °C	2,250	1,980	<b>1,770</b>	1,590	<b>1,450</b>	1,320	<b>1,210</b>	1,110
12	20 °C	<b>2,030</b>	<b>1,780</b>	<b>1,590</b>	1,430	<b>1,300</b>	1,190	<b>1,090</b>	1,000
12	25 °C	1,920	1,690	1,500	1,350	<b>1,230</b>	1,120	<b>1,030</b>	0,940
12	30 °C	1,810	1,590	1,420	1,280	<b>1,160</b>	1,060	<b>0,970</b>	0,890
12	40 °C	<b>1,580</b>	<b>1,390</b>	<b>1,240</b>	<b>1,120</b>	<b>1,020</b>	0,930	<b>0,850</b>	0,780
12	50 °C	1,360	1,200	1,070	0,960	0,880	0,800	<b>0,730</b>	0,670
13	0 °C	2,110	1,850	1,650	1,490	1,360	1,230	<b>1,130</b>	1,040
13	10 °C	1,920	1,690	1,500	1,360	1,230	1,120	<b>1,030</b>	0,940
13	20 °C	1,730	1,520	1,360	1,220	1,110	1,010	<b>0,930</b>	0,850
13	25 °C	<b>1,630</b>	<b>1,440</b>	<b>1,280</b>	<b>1,150</b>	<b>1,050</b>	<b>0,960</b>	<b>0,880</b>	0,800
13	30 °C	1,540	1,350	1,210	1,090	0,990	0,900	0,830	0,760
13	40 °C	1,350	1,190	1,060	0,950	0,870	0,790	0,720	0,660
13	50 °C	1,160	1,020	0,910	0,820	0,750	0,680	0,620	0,570
14	0 °C	1,820	1,600	1,420	1,280	1,170	1,060	0,970	0,890
14	10 °C	1,650	1,450	1,300	1,170	1,060	0,970	0,890	0,810
14	20 °C	1,490	1,310	1,170	1,050	0,960	0,870	0,800	0,730
14	25 °C	1,410	1,240	1,100	0,990	0,910	0,820	0,760	0,690
14	30 °C	1,330	1,170	1,040	0,940	0,850	0,780	0,710	0,650
14	40 °C	1,160	1,020	0,910	0,820	0,750	0,680	0,620	0,570
14	50 °C	1,000	0,880	0,780	0,710	0,640	0,580	0,540	0,490

This table can also be computed by the following formulas (with  $E_0 = 0.322$  mJ and  $R_{mean}$  is the head resistance) :

$$V' = 0,9887V - 0.0226$$

$$t_2 = t_1 \times (0,7191 \times \text{Log}(tm) + 0,6777)$$

$$t_1 = \frac{R_{mean}}{V'^2} \times E_0$$

$$t_{ch} = t_2 \times (-0,0118T + 1,3167)$$

Note : Factors will be different for other papers

### 8.3 APPENDIX 3 : FIT OR CHANGE THE PRINTHEAD

The printhead kit contains the opto-sensor and the flexible, it is necessary to change the whole kit.

Instructions to change printhead :

Make sure the printer is not powered.

Remove existing printhead

- depending on the host design, it may be necessary to remove the mechanism in order to access to the head.
- remove printhead spring
- disconnect the 26ways flex cable
- pull out the printhead

Fit the new one

- fit the new printhead
- connect the 26 ways flex cable
- fit the printhead spring
- re fix the mechanism if necessary.

### 8.4 APPENDIX 4 : FIT OR CHANGE THE COVER

The cover (with its platen) is just clipped to the mechanism. To change it, it is just necessary to open and unclip it, then to clip and close the new one.

Ce document à été crée avec Win2pdf disponible à <http://www.win2pdf.com/fr>  
La version non enregistrée de Win2pdf est uniquement pour évaluation ou à usage non commercial.